

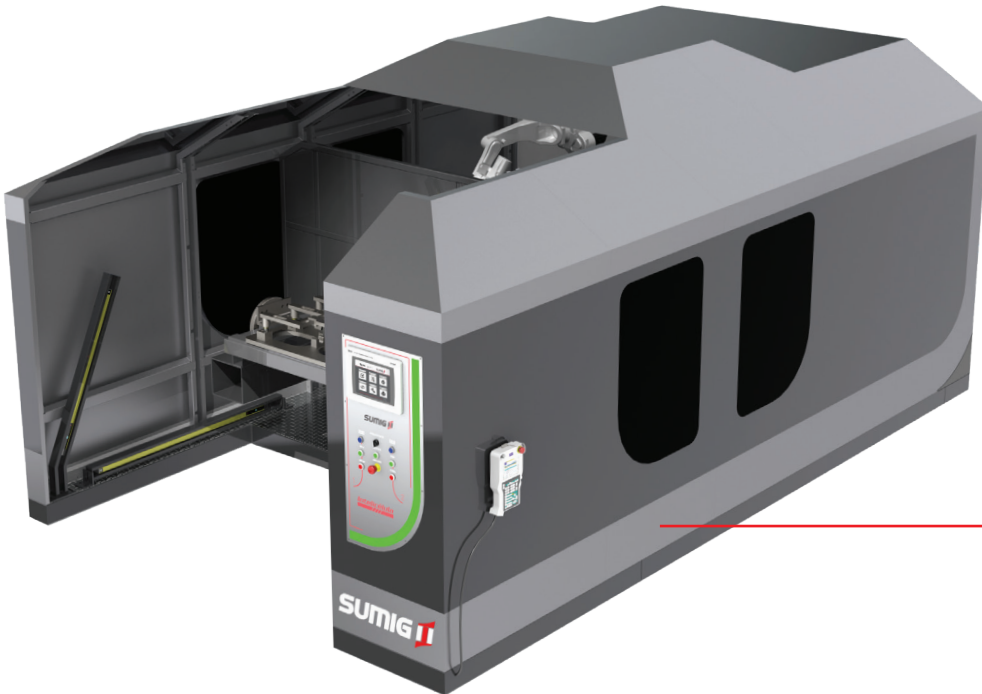

Intelligent Friendly and Intuitive Programming



Equipped with intelligent cell management system

1

Allows connection to the Intellimig Portal and to the cloud

2

Allows use with fume extraction system

3

Visual color alerts that indicate cell status

4

The **Ultimate RS-15** Cell has NEURON-S, the SUMIG Intelligent Interface with two workstations, using robot and source from the same manufacturer for perfect welding communication and synchronism.

The cell has been developed to have optimized work area with fast toolings exchange system and ready to use with fume extraction systems and centralized cleaning unit.

Incluso en el paquete



+



+



The RS-15 model also has the intelligent system and provides resources for welding arc monitoring and quick process fault management with user alert on preventive maintenance.

The built-in Logic Controller with safety functions is certified by TUV and security sensors for robot and power port and safety.

Ultimate Line Differentials:

- Cell and users control;
- Complete machine status display;
- Easy parameterization;
- Process data;
- Communication with the cloud;
- PDF manuals available at NEURON-S;
- Equipment available in: PT - ENG - ESP;
- Easy maintenance due to remote communication (Fieldbus);

Workstation dimensions	750 x 1500 mm
Capacity	1000 kg
Maximum current for power source	63A
Maximum current for controller and robot	16A
Feeding	220V até 460V Trifásico
Dimensions	3000 x 5000 x 2500 mm
Weight	3500 kg
Power	26 kVA
Pressure	6 BAR
Flow by opening and closing the door	8,8 L/s
Size in m ²	15m ²

Measurements

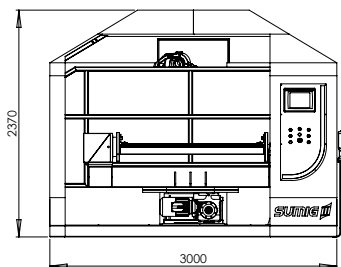

Front

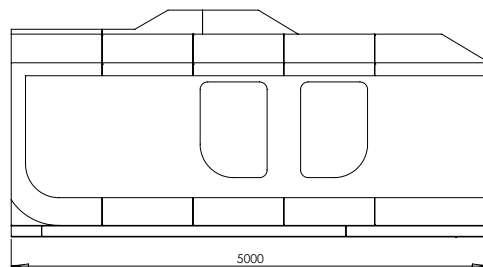

Side

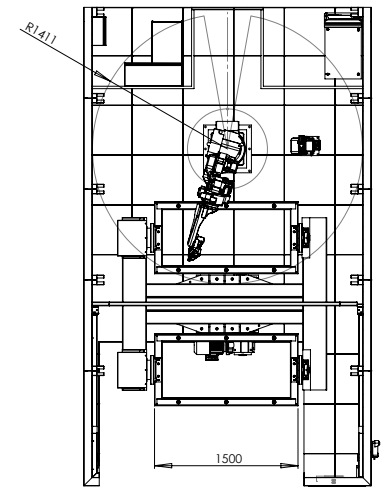

Working Envelope

Standard Components



Robot OTC



WB



SU 477



Cleaner Unit

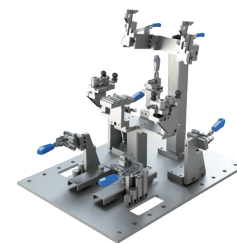

Tooling

Optionals

- Optional - Remote maintenance;
- Optional - Cloud data storage;
- Optional - Communication with Portal for equipment management anywhere in the world;